



**Elkhart
Brass**

Fire Fighting Equipment

**2900E Series
Electrically Actuated
Fire Apparatus Valves**

**INSTALLATION
&
OPERATING INSTRUCTIONS**

Table of Contents

I.	PRODUCT SAFETY	3
II.	SYSTEM DISCRPTION	4
III.	VALVE OPERATION	4
	A. AUTO TRAVEL:	4
	B. INDICATOR LIGHT SIGNALS	5
	C. OTHER CONTROL FEATURES	5
IV.	ELECTRICAL SPECIFICATIONS	6
V.	INSTALLATION INSTRUCTIONS	6
	A. VALVE INSTALLATION	6
	B. VALVE CONTROLLER AND POSITION INDICATOR	9
	C. INTERCONNECTING HARNESSSES	9
	D. PRIMARY/SECONDARY CONTROLLER OPTION	9
VI.	TROUBLESHOOTING	10
VII.	SYSTEM LAYOUT DRAWINGS	11

I. PRODUCT SAFETY:

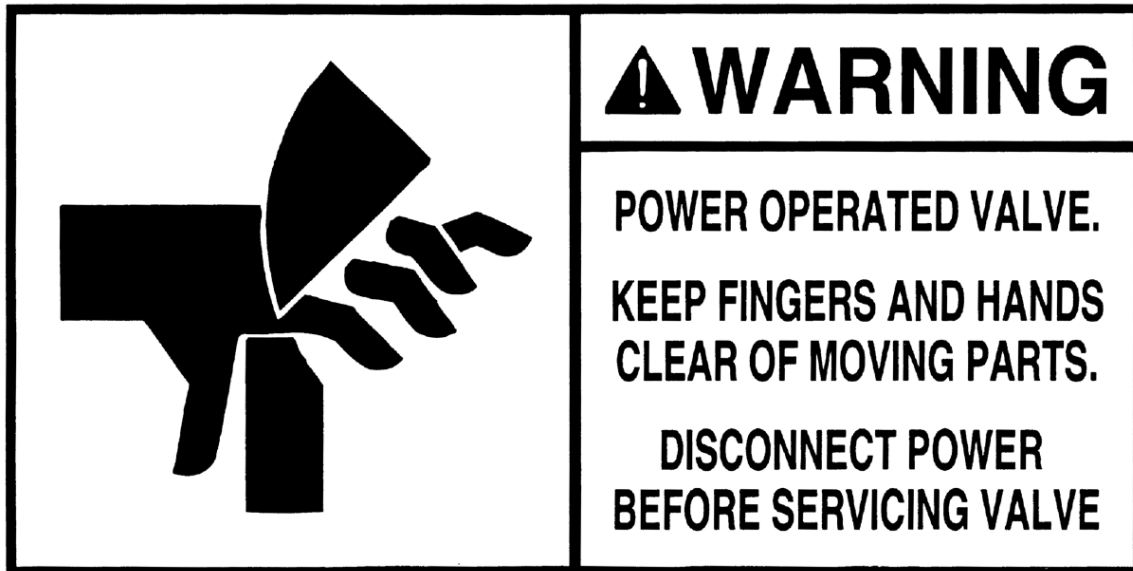

It is critical to the safety of installers, users and bystanders that the following precautions are followed:

1. Keep fingers and hands clear of the valve waterway whenever power is connected to the valve.
2. Be certain that the valve motor power is disconnected prior to servicing the valve.
 - ➔ Motor power can be disconnected by pulling apart the small, two-conductor automotive type wire connector near the valve motor.
3. Whenever valves are installed near hose connections, such that fingers or hands could reach the valve ball or disc, a screen or strainer must be installed in the waterway between the hose connection and the valve.

An adhesive backed warning label, which is supplied with each valve (25024000), should be applied to the pump panel or apparatus body adjacent to the hose connection controlled by an electrically operated valve.

4. A warning label is applied to each valve motor. This label includes a peel-off paint mask. It is important that this mask be removed prior to the apparatus being placed into service.

II. SYSTEM DESCRIPTION:

The 2900E series electrically actuated valve line includes a complete range of ball valve sizes including 1-1/2", 2", 2-1/2", 3", and 4", and butterfly valves in 2", 3", 4", 5", and 6" sizes. The valve opening and closing actions are controlled by a bronze worm gear case driven by a 12 volt DC gear motor. One size gear motor and gear case assembly is used on the 1-1/2", 2", and 2-1/2" ball valves and a larger gear motor and gear case are used on the 3" and 4" ball valves and all sizes of butterfly valves.

Each motor-driven valve is coupled to a combined valve controller and position indicator module (81384001), which includes motor power relays and provides several important operating features. This module is sealed from the environment as long as all harnesses, which use sealed connectors, are connected. The front panel of this module contains two pushbuttons, used to operate the valve, and three high intensity LED's, which indicate the valve's position. Intermediate harnesses from the module to the valve are available from Elkhart Brass in several standard lengths. See Layout Drawings for part numbers.

III. VALVE OPERATION:

The push buttons on the panel-mounted module (81384001) are used to fully open and close the valve or to place the valve in a throttled position. The pushbuttons are color coded for quick interpretation and offer tactile feedback to the user. Pushing the green open button will cause the valve to travel in the open direction, and pushing the red button will cause the valve to travel in the closed direction. When opening the valve from the fully closed position, there is a momentary delay to prevent the valve from being cracked opened by an inadvertent push of the open button.

Hall Effect transducers located in the valve gear case precisely sense the valve open and closed positions. The Hall sensors are digital, solid state devices that provide a switching signal in the presence of a magnetic field. As the valve reaches either the open or closed position, a small magnet moves into the sensing range of the Hall device. The Hall device then changes state and causes motor power to shut off. This control feature prevents high current, high torque stall loading of the motor and gear train.

A. Auto-Travel Feature:

A unique and valuable feature of the 2900E control system is its "Auto-Travel" capability. The travel time from the fully closed to the fully open position is seven seconds for all valve sizes. This travel speed assures precise valve throttling control, and assures against rapid closure of the valve and the associated water hammer potential. The Auto-Travel feature allows the pump operator to either fully open or fully close the valve without the need to hold the pushbutton for seven seconds.

Auto-Travel can be initiated with the valve in any position. To initiate Auto-Travel the operator holds down the pushbutton corresponding to the desired direction of travel. While holding this button, the operator presses and releases the other button. Finally, the operator releases the button corresponding to the desired direction of travel. The valve will continue to travel in the desired direction until it reaches the fully open or fully closed position. For the properly trained pump operator this feature is easy to use, but it is highly unlikely that a less experienced operator will accidentally initiate Auto-Travel. Once Auto-Travel has been initiated, pressing either button will cancel the operation.

B. Indicator Light Signals:

The valve controller/position indicator module (81384001) uses three high intensity LED's, red, amber, and green, for reliable status indication under all ambient lighting conditions. These LED's provide the following signals to the operator:

SIGNAL	MEANING
Steady lit red	Valve ball in the fully closed position
Steady lit green	Valve ball in the fully open position
Steady lit amber	Valve ball is in a throttled position
Steady lit amber with flashing green	Valve ball is moving toward the open position
Steady lit amber with flashing red	Valve ball is moving toward the closed position

C. Other Control Features:

Low Voltage Protection:

Should the valve power source voltage ever drop to six volts or less, the control module automatically prevents application of power to the motor. Low voltage conditions can cause serious damage to DC motors.

Automatic Power Off:

If the valve becomes jammed (ice, debris, or any other reason) while the valve is in Auto-Travel, this feature will automatically shut off motor power after fifteen seconds.

Manual Valve Actuation:

If valve motor power fails for any reason, the valve can be opened or closed manually. Manual actuation is accomplished by turning the hex fitting on the end of the worm drive shaft opposite the motor. Turning the hex fitting clockwise will open the valve, while turning it counterclockwise will close the valve. A 3/4" ratchet box end, standard box end or open-end wrench is recommended for this purpose.

<p><u>NOTE:</u> DO NOT use any motorized or air actuated devices to drive the hex fitting. This will void all warranties.</p>
--

The circuitry within the 81384001 control module is designed to be immune to the effects of reversed polarity of the incoming power. If polarity is reversed at the time of system installation or any time during system maintenance or troubleshooting, no damage will result. None of the LED's will light up and the unit will not function during polarity reversal.

IV. ELECTRICAL SPECIFICATIONS:

Valve Type	3" and 4" Ball Valves All Butterfly Valves	1.5", 2.0", and 2.5" Ball Valves
Nominal Operating Voltage	12 VDC	
Operating Voltage Range	11-15 VDC (RECOMMENDED FUSE RATING 10A)	
Normal Operating Current	3 A	1.5 A
Motor Stall Current	13 A	11.9 A
Operating Temperature Range	-40°F to 150°F	

V. INSTALLATION INSTRUCTIONS:

A. Valve Installation:

The 2900E ball valves sizes 1.5" through 3.0" are bi-directional and can be installed in either direction. The 2940E 4.0" valve should be installed with the arrow on the body pointing in the direction of flow except in a tank to pump application where the arrow should be pointing towards the tank. The 2950E butterfly valves are bi-directional and can be installed in either direction. The 2960E butterfly valves should be installed with the seat towards the pressure source.

NOTE: Some older 2-1/2" ball valve end caps have stepped recesses on the valves' mating surfaces. These stepped endcaps cannot be used with the 2900 valves. Replace these endcaps with new flat surface endcaps.

Motor/Gear Case Repositioning:

The 2900E ball valve and the 2960E butterfly valve gear cases may be installed in one of four positions relative to the valves assemblies' inlet as shown in Figure 1. There are two possible positions for the gear cases used on the 2950E butterfly valves as shown in Figure 2. Since these valves are bi-directional each position can be mounted two ways. The valves shown in Figures 1 and 2 are in the fully closed position. If installation interference is encountered due to gear case position, the following steps will allow simple repositioning of the gear case:

NOTE: Valve actuators should be positioned to provide best access to the 3/4" hex manual override nut.

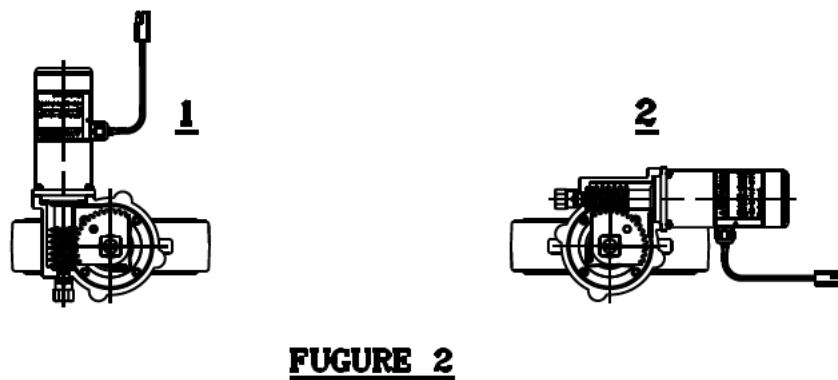
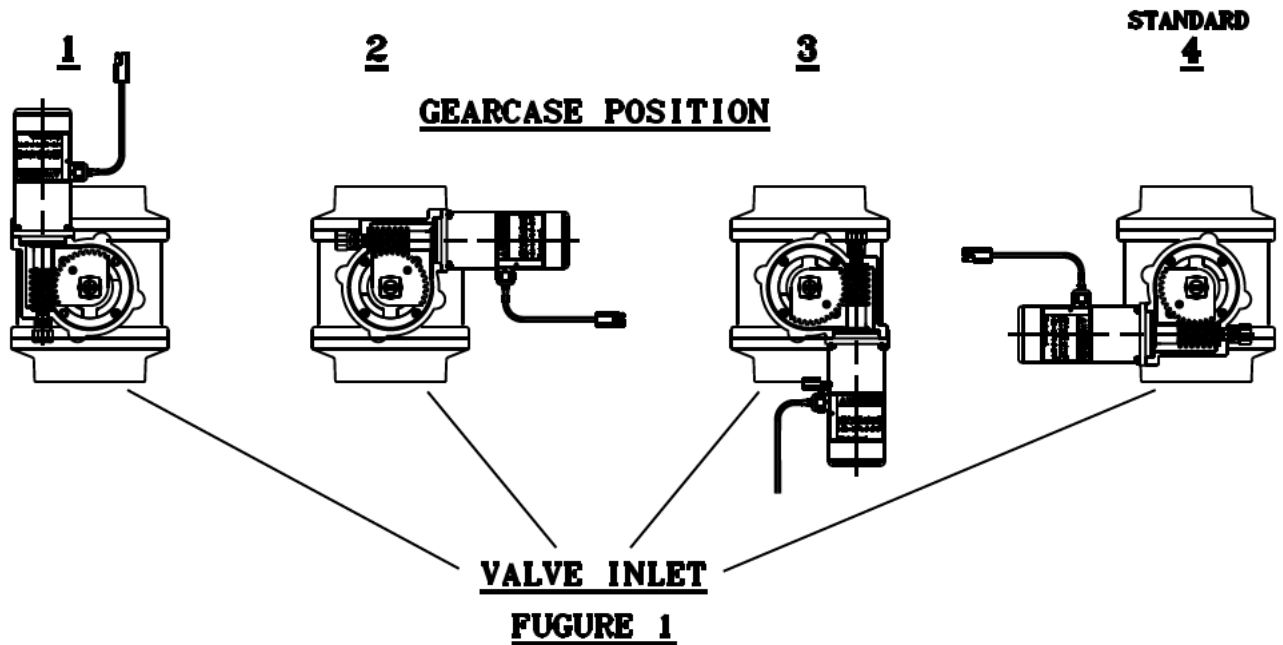

Ball Valves:

1. Place the valve in the fully closed position. Note that the slot in the end of the actuator shaft shows the position of the ball. When the slot is at a right angle to the waterway, the valve is fully closed.
2. Remove the four socket head cap screws from the gear case cover, and then pull the cover from the gear case. Rotating the cover slightly will ease removal.
3. Remove the thrust washer and gear segment from the gear case. Note that rotating the worm slightly will ease gear segment removal.
4. Remove the four socket head cap screws that secure the gear case to the valve body. Do not remove the stop plate from the actuator shaft.
5. Rotate the gear case to the desired position. (Note: Inspect the O-ring between the gear case and the valve body for any damage and proper location.)

6. Apply Loctite #242 to the four screws and reinstall them to secure the gear case to the valve body. Torque the screws to 120-150 in-lbs.
7. Install the gear segment in the correct position as shown in Figure 1 above. Note that rotating the worm slightly will ease gear segment installation.
8. Apply petroleum base grease to the thrust washer and install.
9. Reassemble the gear case cover on the gear case taking care not to damage the cover O-ring.
10. Apply Loctite #242 to the four socket head cap screws and reinstall and tighten them to secure the gear case cover.

Butterfly Valves;

1. Place the valve in the fully closed position. Note that the slot in the end of the actuator shaft shows the position of the disc. When the slot is at a right angle to the waterway, the valve is fully closed.
2. Remove the four socket head cap screws from the gear case cover, and then pull the cover from the gear case. Rotating the cover slightly will ease removal.
3. Remove the thrust washer and gear segment from the gear case. Note that rotating the worm slightly will ease gear segment removal.
4. Remove the four hex head bolts that secure the gear case assembly to the mounting flange on the valve body.
5. Rotate the gear case assembly to the desired position while making sure the valve remains closed.
6. Apply Loctite #242 to the four hex head bolts then reinstall and tighten them to secure the gear case assembly to the mounting flange on the valve body.
7. Install the gear segment in the correct position as shown in Figure 2 above. Note that rotating the worm slightly will ease gear segment installation.
8. Apply petroleum base grease to the thrust washer and install.
9. Reassemble the gear case cover on the gear case taking care not to damage the cover O-ring.
10. Apply Loctite #242 to the four socket head cap screws and reinstall and tighten them to secure the gear case cover.

B. Valve Controller and Position Indicator Module:

The 81384001 valve controller and position indicator module is to be installed in the pump control panel. The panel cutout template is shown on the layout drawing. The module is secured to the pump panel with four split lock washers and four #6-32 stainless steel small pattern nuts (1/4" socket driver), which are provided with the module. The pressure gage for each discharge valve should be installed above the 81384001 module controlling that valve. A harness is included with each control module and is to be connected to the back of the module. This harness contains two male connectors; one for supply power, and one that is to be connected to the valve via an intermediate harness.

NOTE: The 81384001 module is only sealed from the environment when all harnesses are plugged in.

Power Source:

It is recommended that power to all 81384001 valve control modules be controlled by a single switch/relay combination so that power can be shut off unless the apparatus is in pumping mode. Automatic reset circuit breakers must be installed between the power source and the 81384001 modules. A breaker rating of 10 amps is recommended, and two modules may be powered through a single breaker. Each 81384001 module includes an input power connector with red and black wire leads as shown in electrical layout drawing. The leads have crimp connectors with heat shrink tubing. Strip about 5/16" of insulation from the power source wire and insert it into the crimp connector of the red lead on the supplied power connector. Secure the wire lead in the crimp connector with a suitable crimper. Similarly, strip and crimp the ground wire to the black lead on the supplied power connector (*Chassis ground is not recommended*). After crimping, use a heat gun or another heat source to shrink the plastic sleeves until the adhesive melts and flows to seal the connections.

C. Interconnecting Harnesses:

Interconnecting harnesses are provided in several lengths to connect the 81384001 valve controller and position indicator module and the valve assembly. See Layout Drawing for a complete list of harness lengths. These harnesses should be carefully secured to the vehicle frame or other structural members to protect them from abrasion due to vibration. Also, they must not be installed where they could be exposed to temperatures over 160°F. The harnesses must be supported near all connections.

D. Primary/Secondary Controller Option:

The option exists to control a single valve with two controllers. The controllers may be located in different locations on a truck. The dual controller option functions with the use of a primary controller that is connected to the valve via a power/sensor harness. The secondary controller does not utilize a power/sensor harness; rather it is connected to the primary controller by a primary/secondary harness. The secondary harness sends a signal to the primary controller that controls the valve. The primary controller will override the secondary controller. Refer to the Primary/Secondary Layout Drawing for wiring diagram and harness length options. *Primary and Secondary controllers must share a common ground (Chassis ground is not recommended).*

VI. TROUBLESHOOTING:

Problem	Possible Cause	Solution
No LED's light (no valve function)	Power not being supplied to module	Turn on power to module and check circuit breaker
	Module supply power polarity is reversed	Correct power input wires
Alternating flashing red and green LED's when first powered up (no valve function)	Defective switch in controller	Replace controller (Note: must specify whether controller is a primary or secondary when ordering)
Alternating flashing red and green LED's when open or close button is being pushed (no valve function)	Low voltage under load	Check for good power & ground under load
Both red and green LED's on steady (no valve function)	Defective Hall sensor circuit board in valve gear case	Unplug connector at circuit board (mounted to bottom of gear case cover); if yellow LED comes on replace circuit board
	Short in signal wire (orange and/or yellow) between valve and module	Remove harnesses starting at the valve and working back. Replace the last harness you unplug before the yellow LED comes on
Flashing yellow LED	Auto-Travel has timed out after 15 seconds	Hall sensor failure; replace circuit board. Valve jammed; remove debris from waterway. Motor failure; replace motor and look for cause of failure
Red or green LED's will not stay lit. Red or green LED flashes when operating the valve	Defective Hall sensor circuit board	Remove gear case cover. With system power on, hold magnet over sensor and check for steady burning red or green LED. If both LED's don't light in presence of magnet, replace circuit board
	Defective signal wire (orange or yellow) between valve and module	Check harness for broken or frayed wires and examine connectors and/or loose contact crimps
LED will not light	Burned out LED	Replace module
	Failed Hall sensor circuit board	Replace circuit board located on bottom of valve gear case cover
	Damaged or broken wires between valve controller and valve	Check all wires and connections for damage
Valve will not open or close. Lamp flashes, showing direction, but valve does not move	Motor assembly not plugged into harness	Check two prong molded connector at valve and reconnect
	Gear segment not in correct position	Reference motor/gear case repositioning Figures 2 & 3
	Motor is burned up	Remove motor sub from valve and apply 12 VDC to motor. If motor does not operate, replace

VII. SYSTEM LAYOUT DRAWINGS

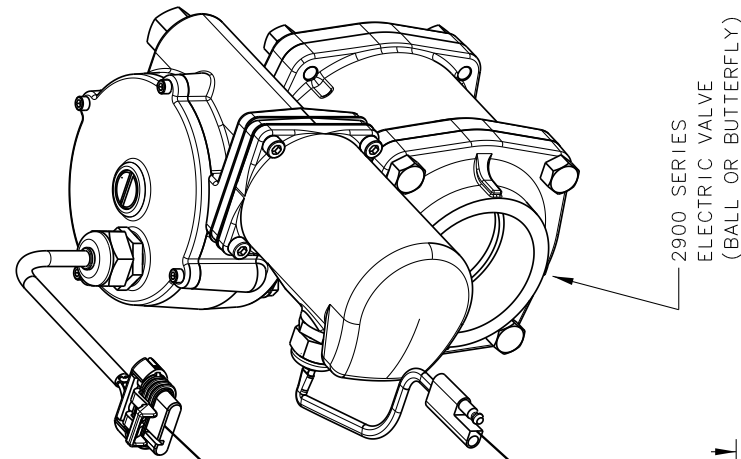

5	36793800	HARNESS (40FT)	POWER/SENSOR	1
5	36793700	HARNESS (20FT)	POWER/SENSOR	1
5	36793600	HARNESS (20FT)	POWER/SENSOR	1
5	36793500	HARNESS (10FT)	POWER/SENSOR	1
5	36793300	HARNESS (5FT)	POWER/SENSOR	1

REQUIRED HARNESS (CHOOSE ONE)

4	51496000	BEZEL CHR9M VALVE CONTROLLER	1
---	----------	------------------------------	---

COMES WITH P/N 81384001 CONTROLLER

3	36792000	HARNESS - POWER	1
2	36823000	HARNESS-CONTROLLER(PRIMARY)	1
1	81384001	VALVE CONTROLLER(PRIMARY)	1

NO.	PART NO.	PART NAME	REQ.
ELKHART BRASS MFG. CO., INC. ELKHART, INDIANA			
ELECTRIC VALVE LAYOUT SINGLE CONTROLLER			
REV.	WAS	EJD	DATE 1/17/05
DESIGNED BY	WAS	DATE	1/17/05
DRW NO.	374		
SCALE	3/4		
STANDARD RELEASE			
3 PLANT ALL RIGHTS RESERVED			
4 PLACE ORDER WITH THESE CORNERS UNLESS OTHERWISE SPECIFIED			
PART NO. 98444000 BALL & BUTTERFLY SDRC (DO NOT SCALE PRINT)			

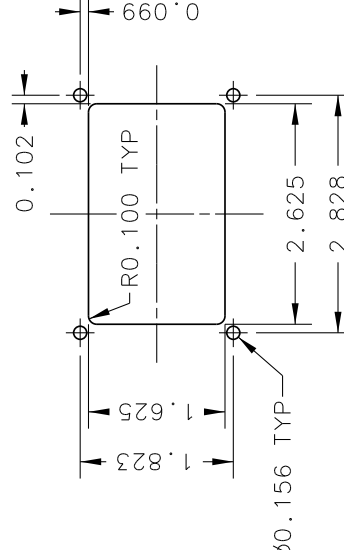
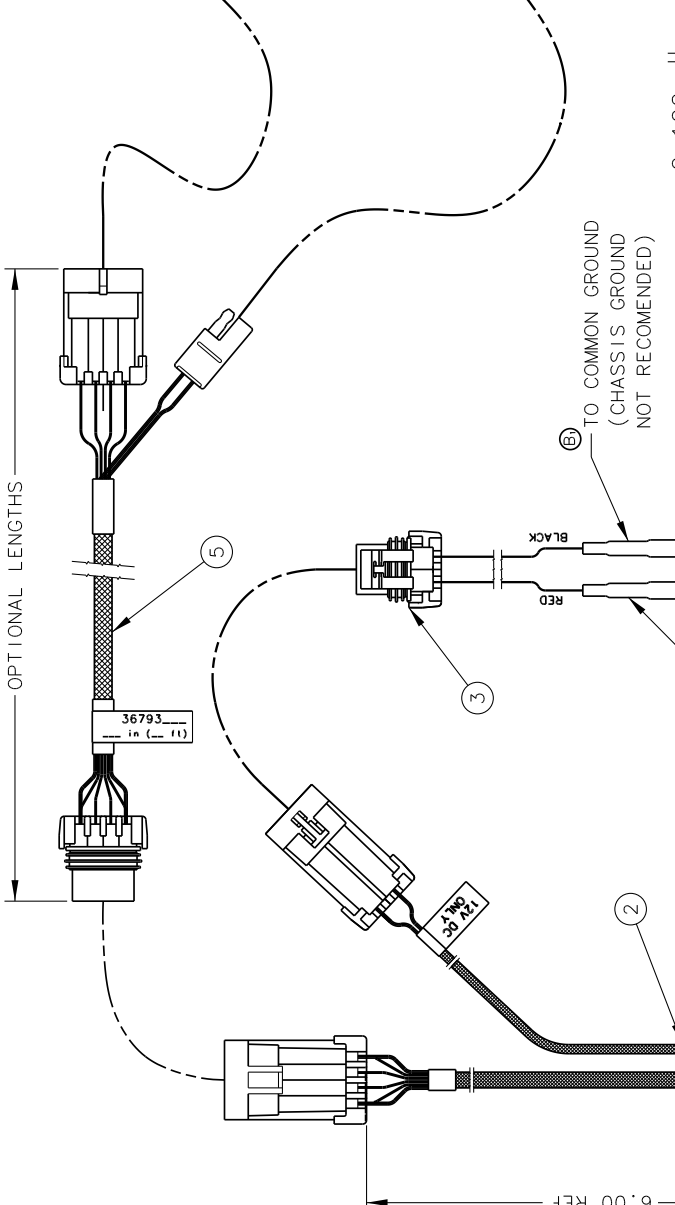

PANEL CUTOUT DETAIL
SCALE: 1" = 1"

NUT P/N 47498000 & LOCK WASHER P/N 71700000
4 EA. SUPPLIED WITH CONTROLLER

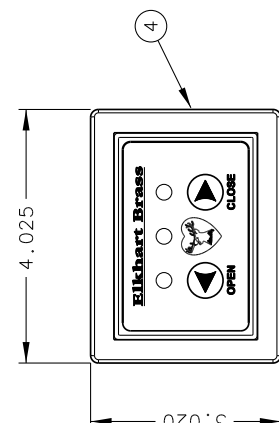

PANEL VIEW WITH BEZEL

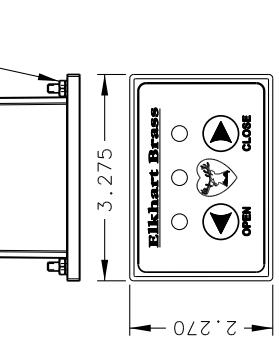

PANEL VIEW WITHOUT BEZEL

